

KB1212EV 12V 13.3h C₂



The Electric Vehicle batteries were developed based on a specialized grid as well as active material. These batteries have anchored plates and a high impact reinforced polypropylene case which can withstand the most extreme environments and vibrations. The KB EV series is constituted of batteries of several different sizes so that they may be used for many different applications. The KB EV series uses dry cell technology that allows for a superior performance and an unparalleled quality and reliability. Through the use of the dry cell technology this series was designed for sensitive environments that require improved life cycles for commercial, industrial, residential and private applications. Without any need for maintenance and with an advanced construction the EV series is an excellent option for many applications.



Dimensions and Terminal (Unit: mm (inches))

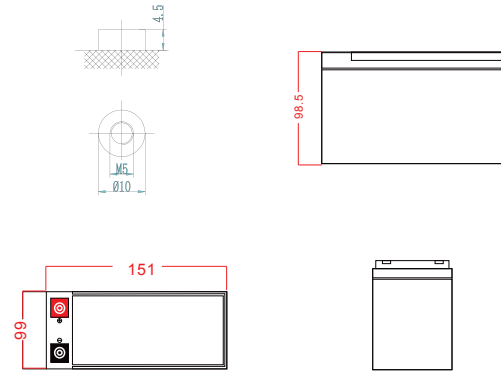

Performance Characteristics

Nominal Voltage	12V	
Dimensions	Length (mm / inch)	151 / 5.9
	Width (mm / inch)	99 / 3.9
	Height (mm / inch)	98 / 3.9
	Total Height (mm / inch)	98.5 / 3.8
	Terminal	M5
Approx. Weight (Kg / lbs)	4.35 / 9.60	
Design Life	5 years	
Container Material	ABS	
Rated Capacity	17.0 Ah / 1.70 A	(10hr, 1.75V / cell, 20°C / 77°F)
	13.3 Ah / 6.65 A	(2hr, 1.75V / cell, 20°C / 77°F)
	11.6 Ah / 11.6A	(1hr, 1.75V / cell, 20°C / 77°F)
Operating Temp. Range	Discharge : -20 ~ 50°C (-4 ~ 122°F)	
	Charge : -20 ~ 50°C (-4 ~ 122°F)	
	Storage : -20 ~ 50°C (-4 ~ 122°F)	
Charge Method	Float use: 13.7-13.9V at 25°C (77°F)	
	Cycle use: 14.7-14.9V at 25°C (77°F)	
	Max charge current 2.66A	
Self Discharge	Fully charged Kaise Electric Vehicle batteries may be stored for up to 6 months at 25°C (77°F) and then a freshening charge is required. For higher temperatures the time interval will be shorter.	

Applications

- Electric wheelchair
- Electric vehicle / golf car
- Electric toys
- Renewable energies
- Marine equipment

Certifications

ISO 9001:2008 ISO 14001:2008



Discharge Current vs. Discharge Voltage

Final discharge voltage V/CELL	1.8	1.75	1.7	1.6
Discharge current (A)	I ≤ 0.1CA	0.25CA ≥ I > 0.1CA	0.55CA ≥ I > 0.25CA	I > 0.55CA

Constant Current Discharge (Amperes) at 25°C (77°F)

Volts/cell	5min	15min	30min	1h	2h	5h	10h	20h
1.80V	47.9	28.7	18.7	11.3	6.53	3.14	1.69	0.903
1.75V	53.5	30.8	19.5	11.6	6.65	3.23	1.70	0.908
1.70V	58.1	31.8	19.7	11.8	6.76	3.27	1.72	0.912
1.65V	60.6	32.5	20.1	11.9	6.81	3.30	1.74	0.917
1.60V	62.5	33.6	20.4	11.9	6.84	3.33	1.76	0.922

Constant Power Discharge (Watts per cell) at 25°C (77°F)

Volts/cell	5min	15min	30min	1h	2h	5h	10h	20h
1.80V	85.8	53.9	35.5	21.9	12.7	6.13	3.24	1.79
1.75V	93.4	57.0	36.4	22.0	12.8	6.20	3.27	1.80
1.70V	100	57.4	36.6	22.2	12.9	6.24	3.31	1.81
1.65V	101	58.1	36.6	22.4	12.9	6.29	3.34	1.81
1.60V	105	59.1	36.9	22.6	12.9	6.32	3.38	1.82

(Note) The above characteristics data are average values obtained within three charge/discharge cycles not the minimum values.

Discharging Characteristic

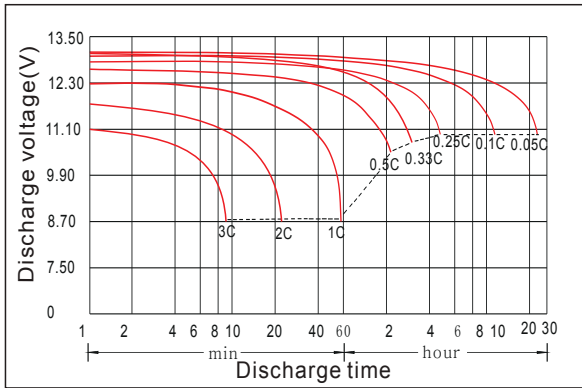

Charging Characteristics

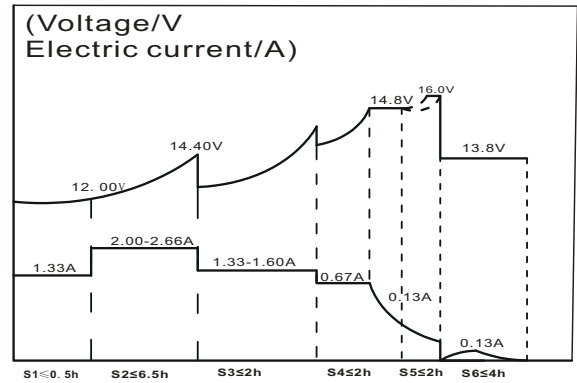

The effect of discharge depth on cycle life

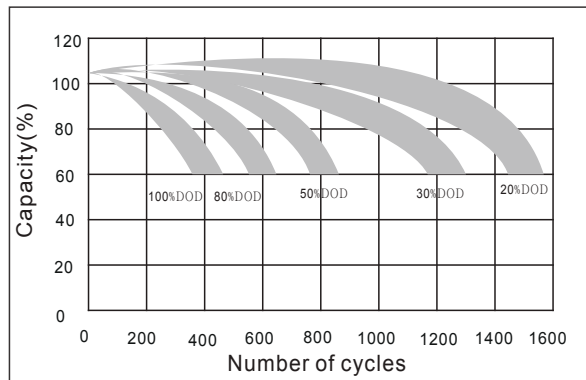

Temperature Effects on Capacity

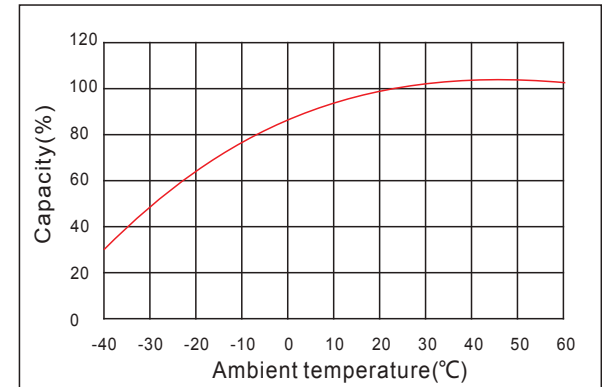

Curves of self-discharge

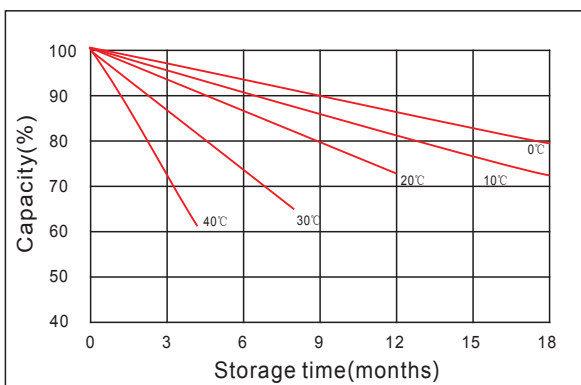

Curves of open circuit voltage vs. capacity

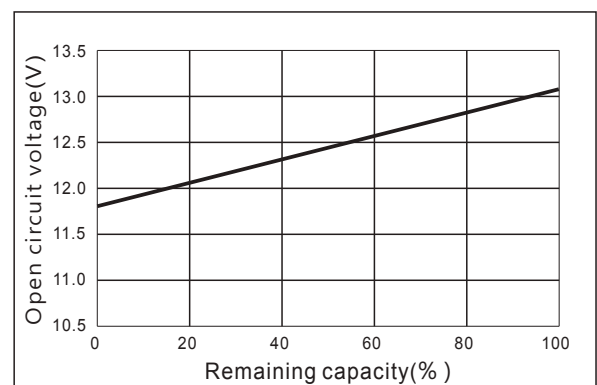

IMPORTANT NOTE: The specifications presented herein are subject to revision without notice.

2024/1K

